

- 1
- 2
- 3
- 4
- 5
- 6
- 7
- 8
- 9
- 10
- 11
- 12
- 13
- 14
- 15
- 16
- 17
- 18
- 19

**MATERIAL**

Edelstahl 1.4401

**STANDARDAUSFÜHRUNGEN**

- **DIN 6319-C-A4:** Kugelscheibe.
- **DIN 6319-D-A4:** Kegelpfanne mit  $d_3 = d_2$ .

**FUNKTIONEN UND ANWENDUNGEN**

Kugelscheiben und Kegelpfannen DIN 6319-A4 werden eingesetzt, wenn sich Spannelemente an nicht parallele Flächen anpassen sollen.

**SONDERAUSFÜHRUNGEN AUF ANFRAGE**

DIN 6319-G-A4: Kegelpfanne mit  $d_4 > d_2$ .

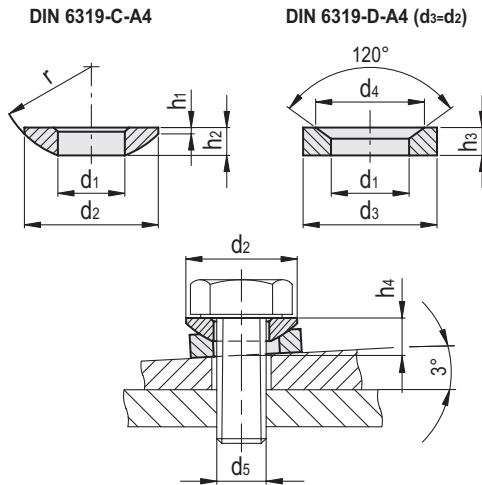
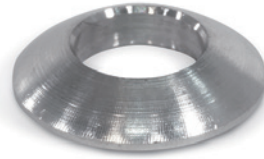

**DIN 6319-C-A4**

Artikelnummer	Beschreibung	d1 H13	d2	d5 Schraube	h1	h2	h4	r	Max. statische Schraubenkraft [kN]	⚖️
GN.30833	DIN 6319-6,4-C-A4	6.4	12	M 6	0.7	2.3	4.2	9	6	2
GN.30837	DIN 6319-8,4-C-A4	8.4	17	M 8	0.6	3.2	5.6	12	10	3
GN.30843	DIN 6319-10,5-C-A4	10.5	21	M 10	0.8	4	6.5	15	17	7
GN.30847	DIN 6319-13-C-A4	13	24	M 12	1.1	4.6	8	17	25	8
GN.30853	DIN 6319-15-C-A4	15	28	M 14	1.2	5	8.5	22	34	11
GN.30857	DIN 6319-17-C-A4	17	30	M 16	1.3	5.3	9.6	22	47	13
GN.30863	DIN 6319-21-C-A4	21	36	M 20	2	6.3	11.7	27	73	22
GN.30867	DIN 6319-25-C-A4	25	44	M 24	2.4	8.2	15.2	32	105	43
GN.30873	DIN 6319-31-C-A4	31	56	M 30	3.6	11.2	19.2	41	168	110

**DIN 6319-D-A4**

Artikelnummer	Beschreibung	d1 H13	d2	d3	d4	d5 Schraube	h3	h4	Max. statische Schraubenkraft [kN]	⚖️
GN.30903	DIN 6319-7,1-D-A4	7.1	12	12	11	M 6	2.8	4.2	6	2
GN.30907	DIN 6319-9,6-D-A4	9.6	17	17	14.5	M 8	3.5	5.6	10	4
GN.30913	DIN 6319-12-D-A4	12	21	21	18.5	M 10	4.2	6.5	17	7
GN.30917	DIN 6319-14,2-D-A4	14.2	24	24	20	M 12	5	8	25	10
GN.30923	DIN 6319-16,5-D-A4	16.5	28	28	24.8	M 14	5.6	8.5	34	16
GN.30927	DIN 6319-19-D-A4	19	30	30	26	M 16	6.2	9.6	47	18
GN.30933	DIN 6319-23,2-D-A4	23.2	36	36	31	M 20	7.5	11.7	73	31
GN.30937	DIN 6319-28-D-A4	28	44	44	37	M 24	9.5	15.2	105	61

Standard Maschinenelemente